

Wymiar otworu arkusz 2, siły arkusz 3

Checklist before order approval: The following information shall be verified prior to the lift order approval. We ask you to verify the information below before order approval.

1. Check the specified lifting height. The lifting height is calculated from floor to floor, the pit dimension shall NOT be included.
2. Shall wall construction, the type of shaft elements (glass, steel) and their placement.
3. Placement (side A, B or C) hanging (left, right) and door type (aluminum, steel)
4. Placement of the electrical compartment.
5. Lift unit placement, side D of the lift unit shall be placed against a wall, as shown on sheet one (1) "Shaft drawing".
6. Check the layout of the control panel, specifically the control buttons.
7. Builder to provide support at the rear of the lift mechanism at a height marked on side D for fixing. There shall be two (2) fixing taken at each support center. 5 kN push in / pull out load shall be imposed on the building structure at each fixing point. Refer to sheet three (3), "Loads and forces" principal drawing.
8. A suitable sized pit shall be excavated with a smooth and leveled bottom surface +10 mm. Refer to sheet number two (2), under "Cut out sizes principal drawing".
9. Control and measure the pit cut out.
10. If a pit is required, check the measured pit depth. If no pit is required, the installation area shall be cleared of debris and leveled. Pit shall floor to be able to accommodate loads noted on the drawing. Refer to sheet three (3), "Loads and forces", specifically "Loads sustained by shaft and platform and fixing points bottom frame".
11. Check if there is an underfloor heating present in the pit and mark its placement. Note that, this section will be bolted in several places.
12. The lift bottom frame is fastened to the floor by means of M8x82 screw expanding anchor bolts, as shown on sheet three (3), "Loads and forces" principal drawing. The lift will also be fixed back at the upper landing door sill(s).
13. Check the specified cut out dimensions necessary for the doors, refer to sheet three (3), "Cut out" principal drawing, specifically table "Door front cut out sizes".

Check list before installation:
The following information shall be verified prior to the lift installation. We ask you to verify the information before proceeding to install the unit on site.

1. A lifting eye bolt, supplied by others; is required at the top of the lift shaft with a minimum safe working load of 500 Kg. Fixture to be positioned approx. 40-50 mm above the required installation headroom, central to the lift depth for stability and approximately 200 mm in from side D. The lifting beam should be clearly marked to carry the load requested. Refer to sheet one (1) "Positioning of the machinery".
 2. Scaffolding with fall protection shall be erected on the top floor; it should support the weight of a minimum of two (2) installers plus tools (approx. 300 kg). Plating shall cover the entire recess 500 mm outwards of side D (or the machine side).
 3. Is work is to be carried out on roofs, the scaffold and work platforms to be used shall be sized and adapted to the job that needs to be performed.
 4. Roof access and safety measurements shall be implemented, if roof work is to be carried out.
 5. The installation area and access route shall be cleared of debris, wires, waste and access personnel, for the duration of the lift installation. A secured area shall be made available adjacent to the installation for storage of tools and equipment. A safe working area 1500 mm back from the landing edge by full width of the lift shaft is required at each level for the duration of the installation. Doorways and passages with a width and height of 1500 x 2100 mm. Note that the platform is able to be dismantled; if the platform is taken apart the necessary working area will be of 900 mm instead.
 6. Builder shall provide hoardings and barriers to protect upper landings for the duration of the installation; the evacuation route should be adequately illuminated.
 10. Power supply shall be available for the use of power tools, etc. Coordinate the work according to ASF 1999:3.
- Power supply and Communication devices
Refer to sheet one (1) "Shaft drawing" under Options for inf. about power supply and phone options. A permanent power supply needs to be installed by others from day one.

Opcja
 automatyczne oświetlenie szybu
 FO 3x400VAC 50Hz 16A 5x2,5mm²
 Udźwig: 1000 kg
 Baterijny zjazd awaryjny sterowany z szafy sterowej

Zatwierdzone przez producenta:

European view placement:



*Przycięty panel
 **Specjalny panel

Nazwa, ściana drzwi:
 E=Osłona napędu
 At the start of the lift installation a lifting eye bolt for a rated load of 500 kg has to be provided at the position of the symbol marked on the drawing

| | | | |
|------------------|--|--------|---------|
| Oferta | 151086-W | | |
| Zamówieni | Rysunek schematyczny A8000 - 1105*2180 Shaft drawing Cibes A8000 - wersja nieprzelotowa RehaLIFT www.rehalift.pl / biuro@rehalift.pl | | |
| Gen. Tolerances | Data | Arkusz | Skala: |
| SS-ISO 27681-1 m | 2017-01-14 | 1 of 6 | A3, 1:1 |

Wymiary otworu w stropie

Wymiar otworu w stropie

| Otwór na drzwi z ościeżnicą | | |
|-----------------------------|-----------|----------|
| Przystanek | Szerokość | Wysokość |
| A 0 | 1525 | 2250 |
| A 1 | 1525 | 2250 |

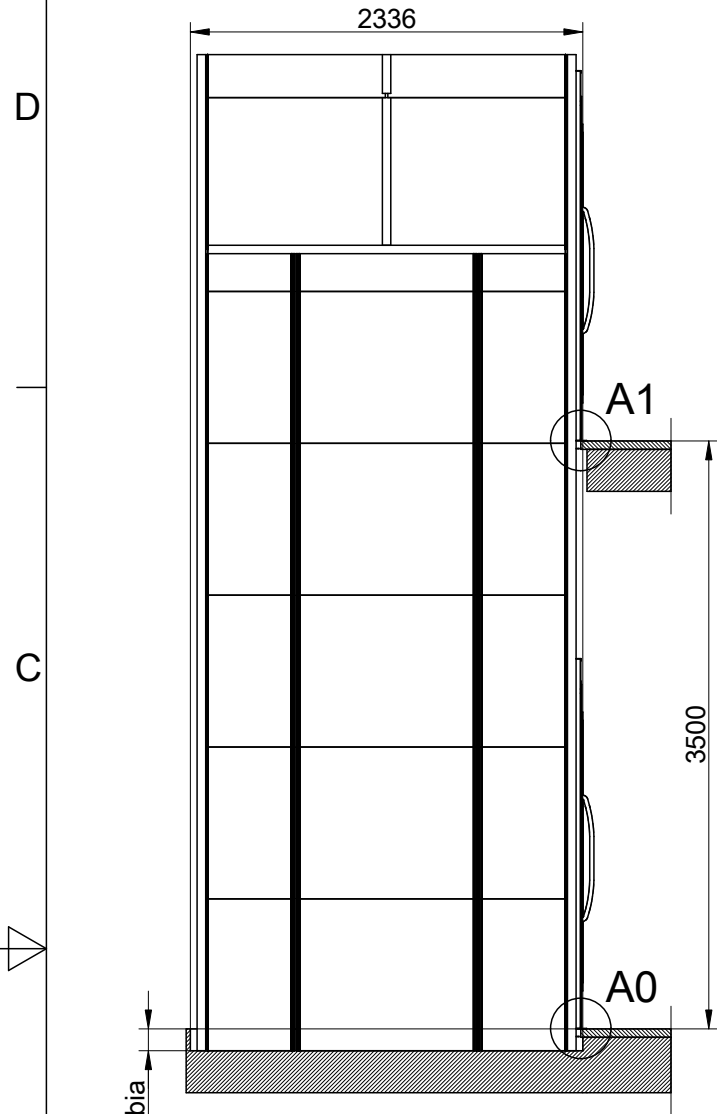

Przekrój E-E

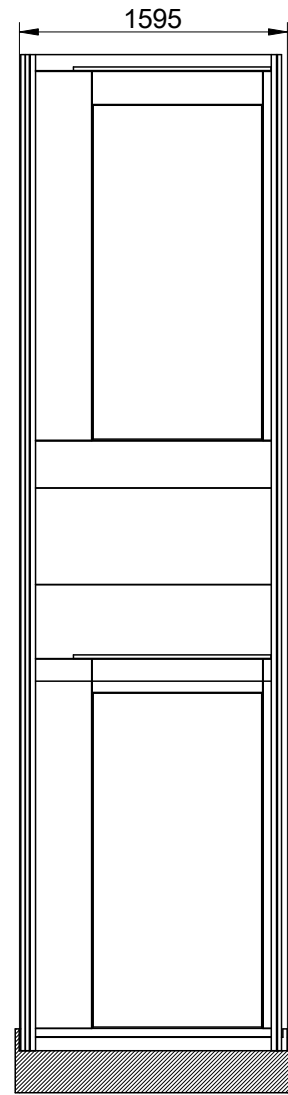

Przekrój G-G

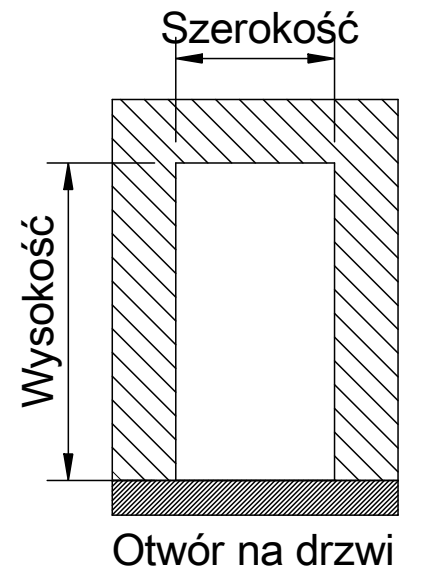
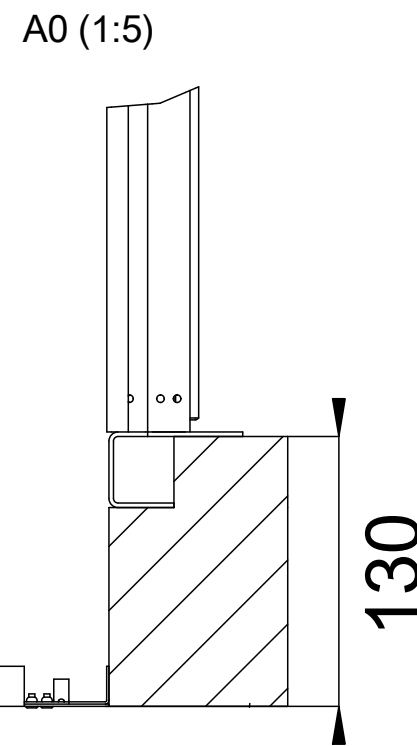
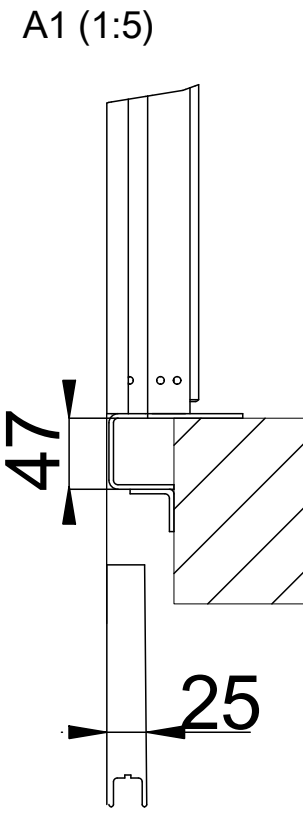

130 mm Głębokość podszybia

130 mm podszybie, powinno być płaskie, tolerancja +10 mm

Zasilnie jest podłączone na przystanku: 0, ściana A

A. Szyb należy oświetlić z zadawalający stopniu

-Zawsze podłącza się telefon
-Dźwig wyposażony w falownik nie podłącza się po przez wyłącznik różnicowoprądowy

Następujące sygnały można przekazać z platformy:

Sygnal wzywania pomocy: Na karcie alarmu kontakt zwarciovy (potencjalnie wolny) na zacisku 4 między miejscem 1 i miejscem 2, kiedy żółty przycisk wzywania pomocy jest wciśnięty przez 10 sek.

Monitorowanie dźwigu: Informację o ew. będzie (8 rodzajów) można przesłać do lokalnej centrali alarmowej z złącza 3, miejsca 14 (N.C.) 15 (N.O.) i 16 (COM) na karcie alarmu.

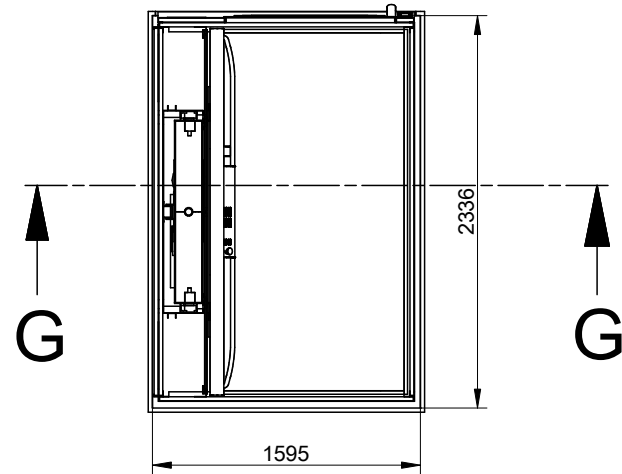
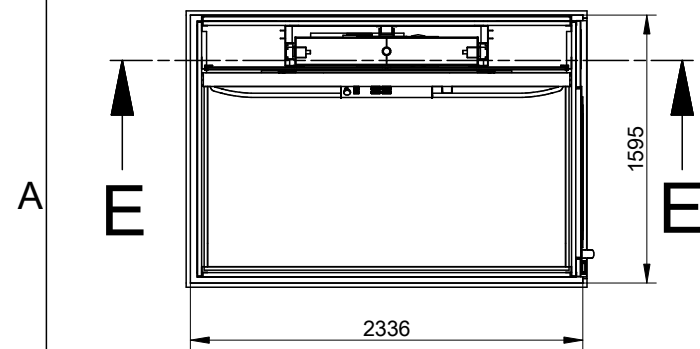
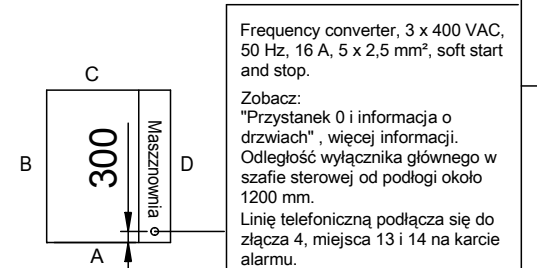

Zatwierdzone przez producenta:

European view placement:



Oferta

151086-W

Zamówieni

Gen. Tolerances

SS-ISO 27681-1 m

Rysunek schematyczny

A8000 - 1105*2180

Cut out sizes

Cibes A8000 - wersja nieprzelotowa RehaLIFT

www.rehalift.pl / biuro@rehalift.pl

Data

2017-01-14

Arkusz

2 of 6

Skala:

A3, 1:1

6 5 4 3 2 1

Siły wywierane przez szymb i platformę
i punkty kotwienia ramy dźwigu

Rekomendacja kotwienia
Obciążenie na punkt kotwienia, $F = 4 \text{ kN}$

A (1:5)



Siła działająca na powierzchnię pod platformą: 4.44 kN
Obciążenie powierzchni pod platformą: 14.56 kN/m^2



Siła działająca na powierzchnię pod помещением машинной: 15.23 kN
Obciążenie powierzchni под помещением машинной: 122.82 kN/m^2

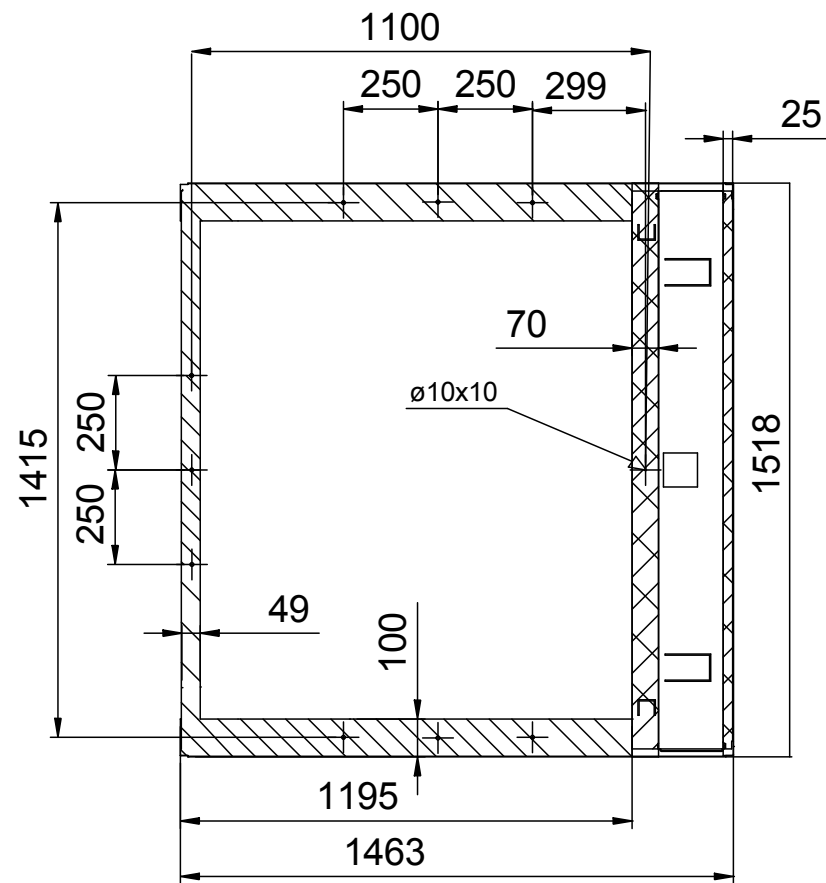

Skala: 1:20

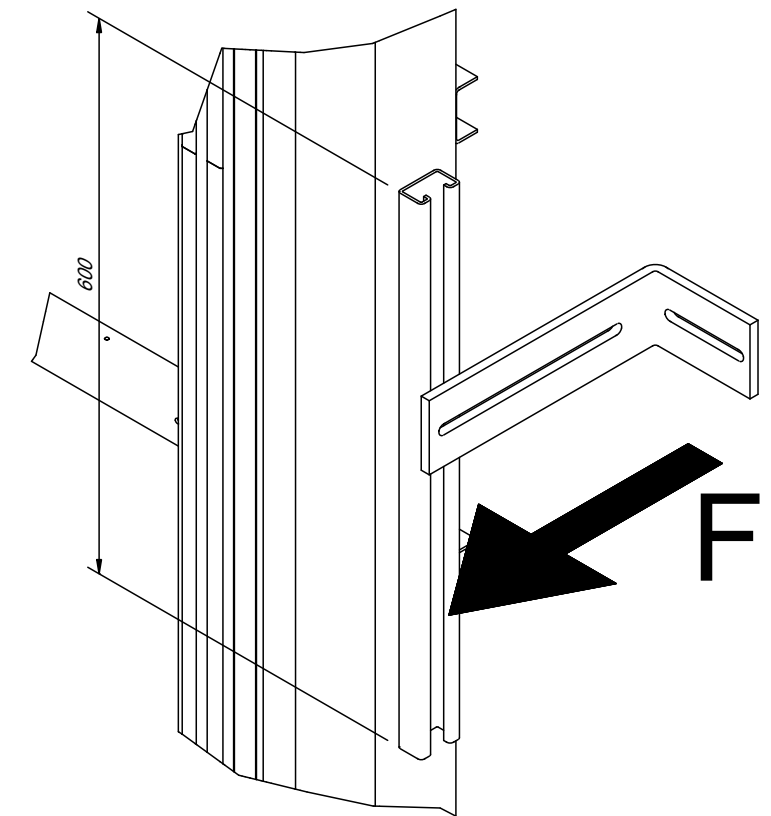
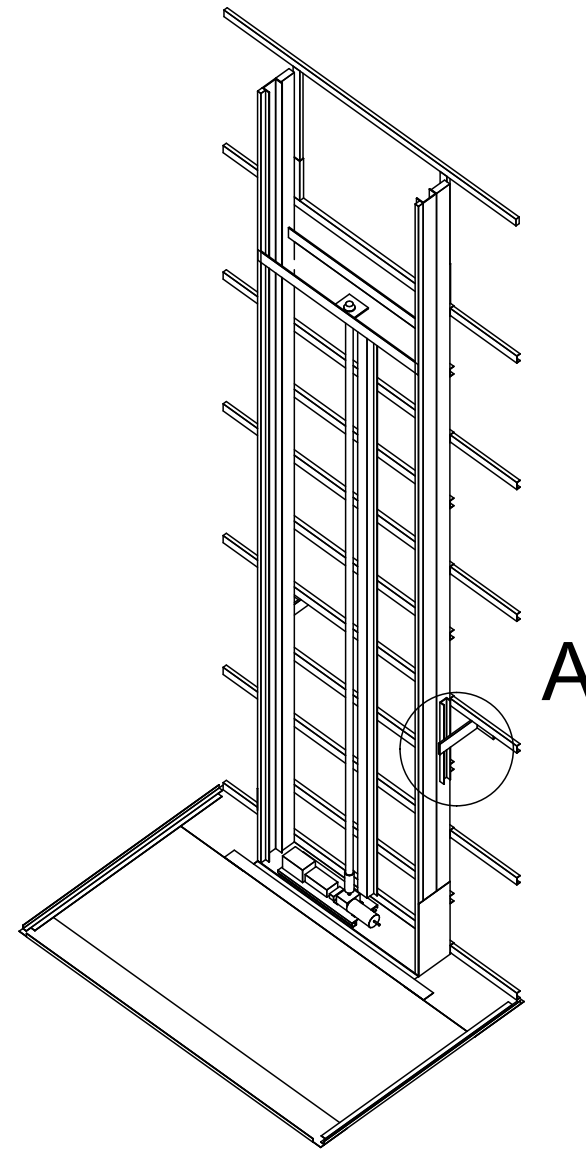

Zatwierdzone przez
producenta:

European view placement:



Oferta

151086-W

Zamówieni

Gen. Tolerances

SS-ISO 27681-1 m

Rysunek schematyczny

A8000 - 1105*2180

Loads and forces

Cibes A8000 - wersja nieprzelotowa
RehaLIFT

www.rehalift.pl / biuro@rehalift.pl

Data

2017-01-14

Arkusz

3 of 6

Skala:

A3, 1:1

6 5 4 3 2 1

Przystanek 0 i informacja o drzwiach

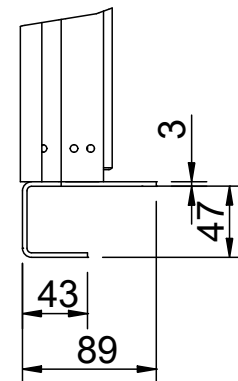
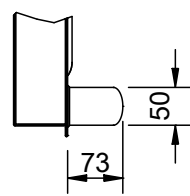
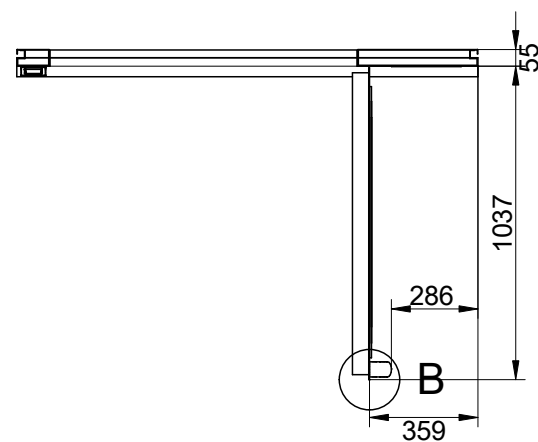
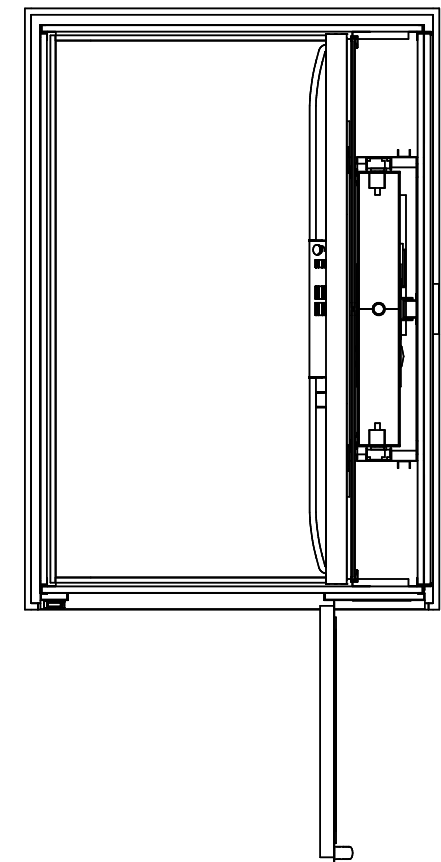
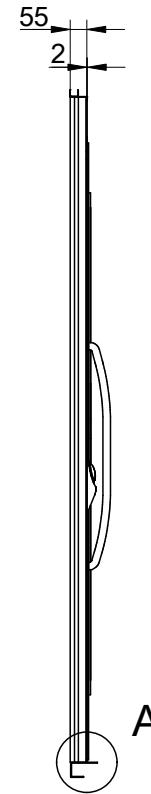
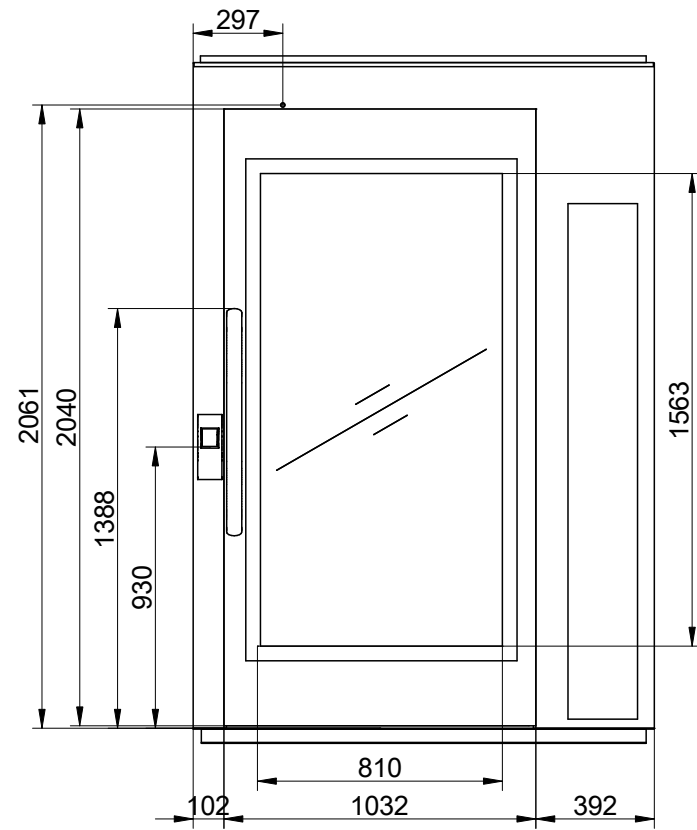
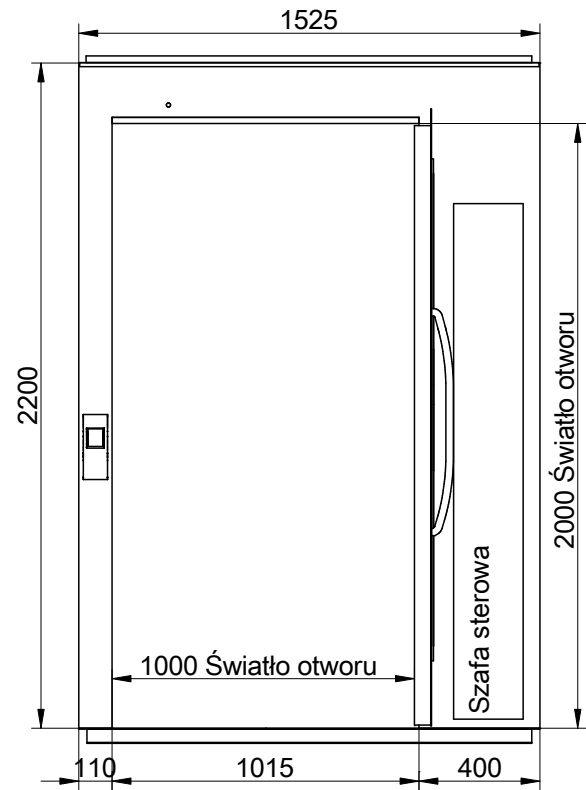

A (1:5)

B (1:10)

Skala: 1:30

| Przystanek | Rodzaj drzwi |
|------------|--------------|
| 0 | A40 |
| 1 | A40 |

Zatwierdzone przez producenta:

European view placement:



Oferta
151086-W

Zamówieni

Gen. Tolerances
SS-ISO 27681-1 m

Rysunek schematyczny
A8000 - 1105*2180
Landing information
Cibes A8000 - wersja nieprzelotowa
RehaLIFT
www.rehalift.pl / biuro@rehalift.pl

Data
2017-01-14

Arkusz
4 of 6

Skala:
A3, 1:1

Przystanek 1 i informacja o drzwiach

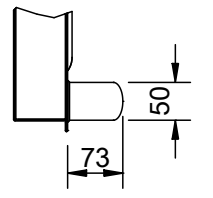
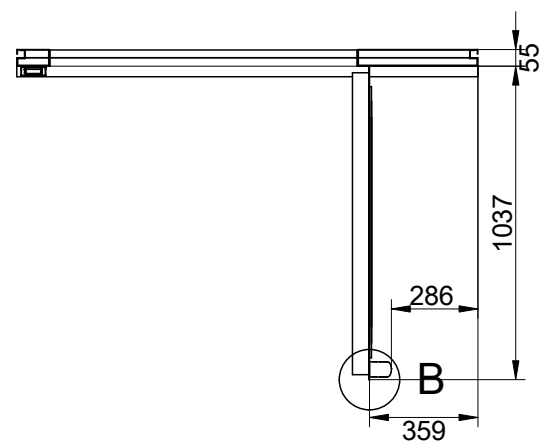
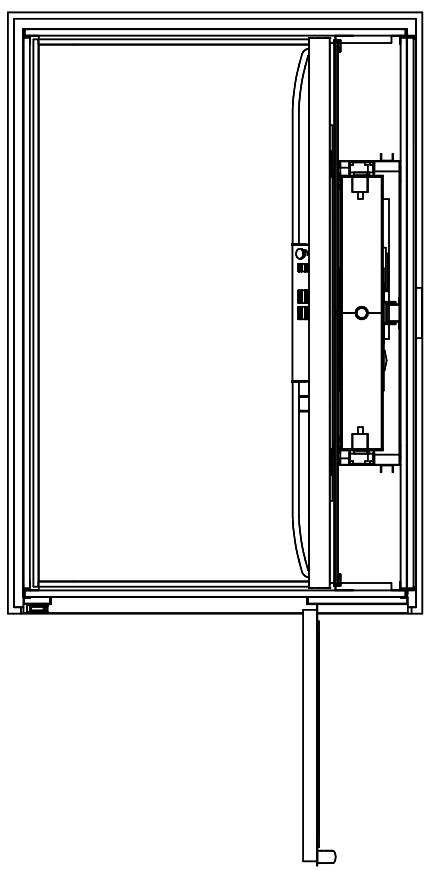
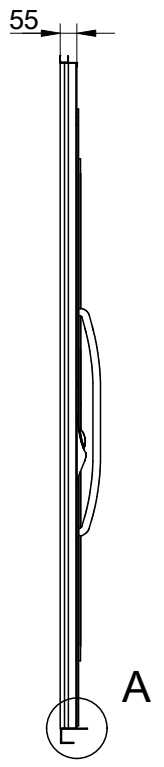
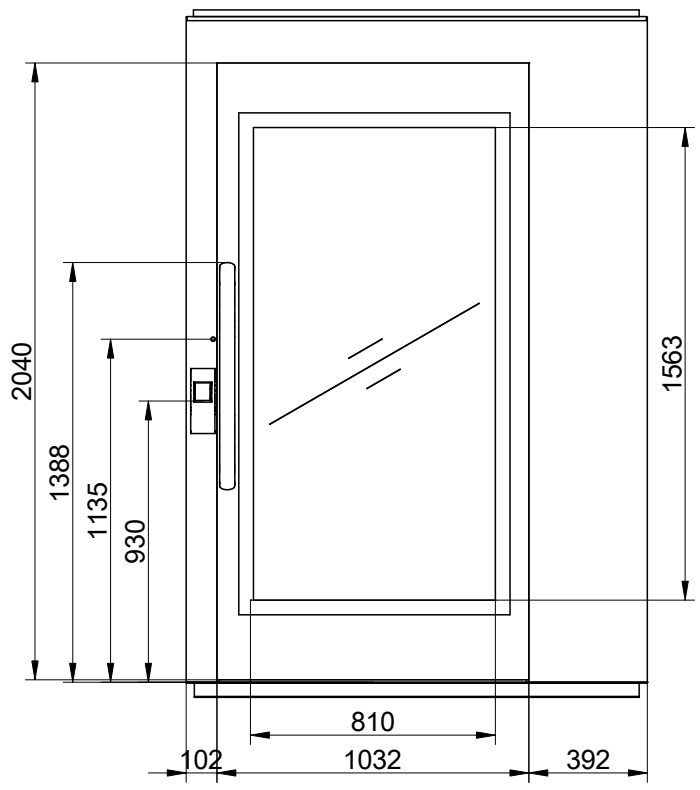
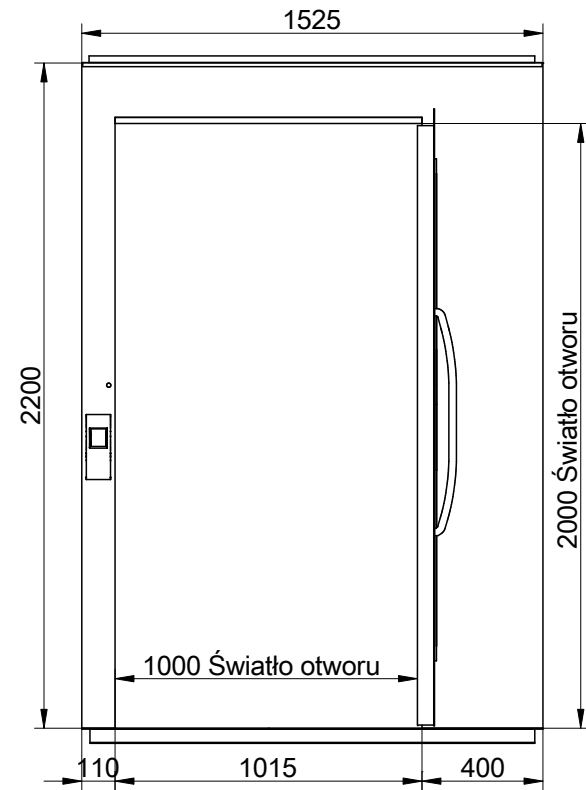

B (1:10)

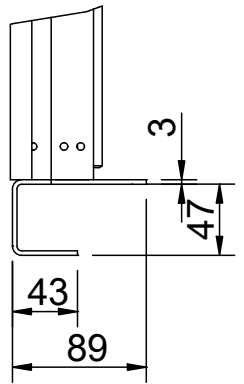

A (1:5)

Skala: 1:30

| Przystanek | Rodzaj drzwi |
|------------|--------------|
| 0 | A40 |
| 1 | A40 |

Zatwierdzone przez producenta:

 European view placement:



Oferta
 151086-W
 Zamówieni

Rysunek schematyczny
 A8000 - 1105*2180
 Landing information
 Cibes A8000 - wersja nieprzelotowa
 RehaLIFT
 www.rehalift.pl / biuro@rehalift.pl
 Gen. Tolerances
 SS-ISO 27681-1 m
 Data
 2017-01-14
 Arkusz
 5 of 6
 Skala:
 A3, 1:1

Wygląd platformy

Skala: 1:20

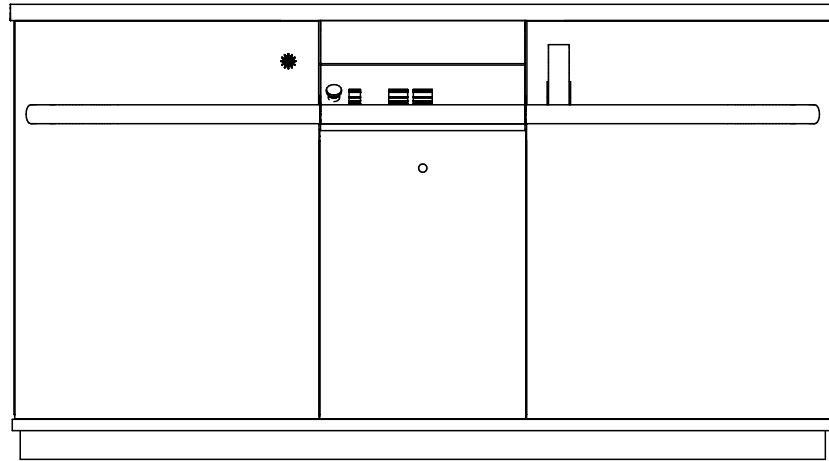

Skala: 1:20

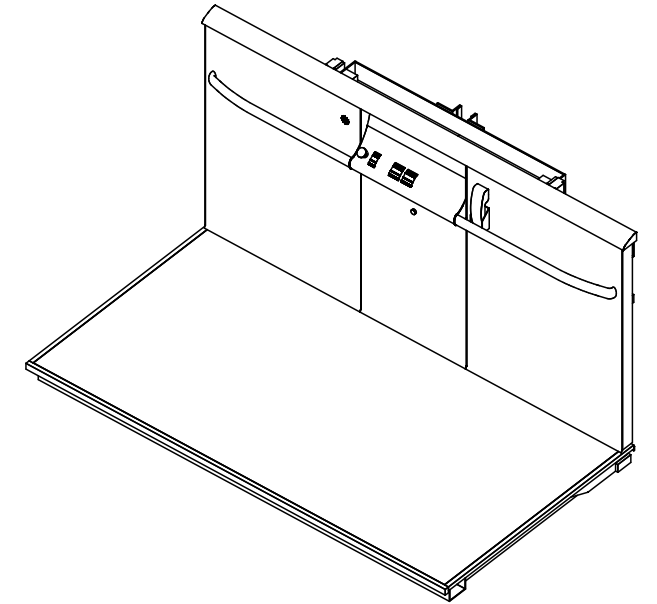
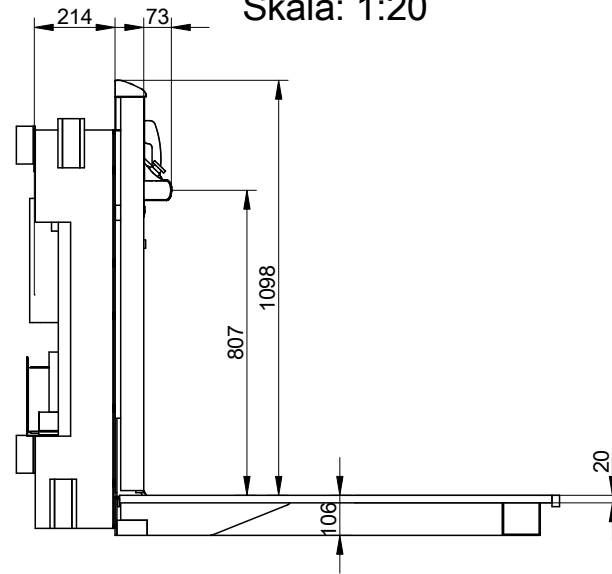

Wymiary platformy
Skala: 1:20

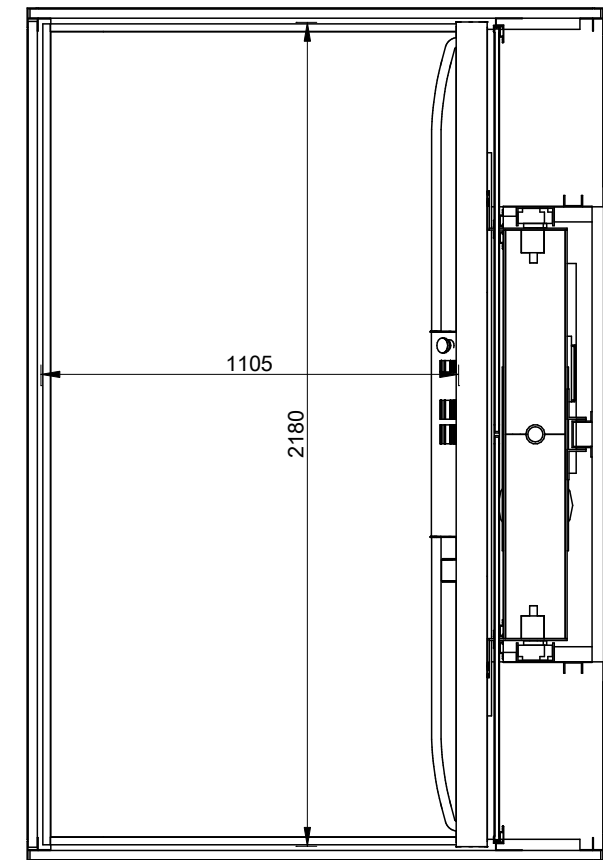

Konfiguracja pulpitu sterującego
Skala: 1:10

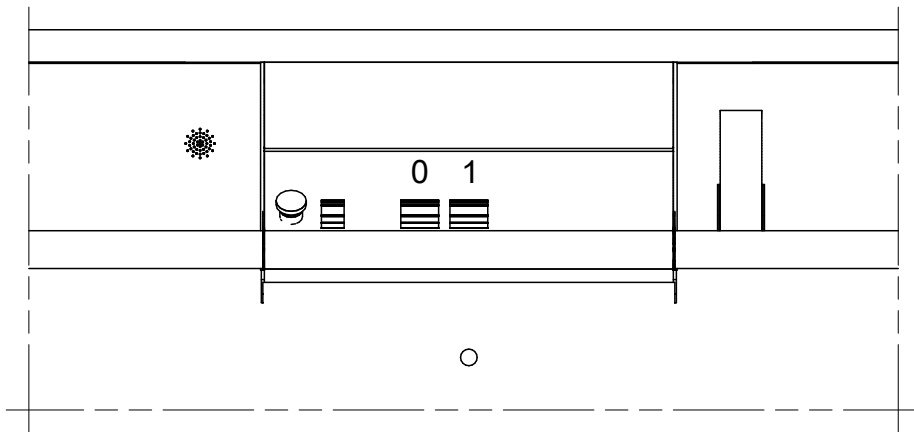

Zatwierdzone przez
producenta:

European view placement:



Oferta

151086-W

Zamówieni

Gen. Tolerances

SS-ISO 27681-1 m

Rysunek schematyczny

A8000 - 1105*2180

Platform layout

Cibes A8000 - wersja nieprzelotowa
RehaLIFT

www.rehalift.pl / biuro@rehalift.pl

Data

2017-01-14

Arkusz

6 of 6

Skala:

A3, 1:1